

CNC BRIDGE SAWS

*Segatrici a ponte
a controllo numerico*

**INSPIRED
BY YOU**



STAR | NEW CHAMPION | TANGO



INSPIRED BY YOU

Ispirati da Voi

The machines of the Prussiani Engineering company are born and developed technologically based on the different needs of the Customer. The company builds **custom-made machines, designed to meet specific needs**. Customer's requests become the incentive for an increasingly advanced technological research. **Together**, company and Customers, reach success, stimulating each other.

“In Prussiani every Customer is special and special is the machine that we create for him”



Le macchine dell'azienda Prussiani Engineering nascono e si sviluppano tecnologicamente in base alle diverse esigenze del Cliente. L'azienda costruisce macchine 'su misura', ideate per rispondere a bisogni specifici. Le richieste dei Clienti diventano lo stimolo per una ricerca tecnologica sempre più avanzata. Insieme, azienda e Clienti, raggiungono il successo, stimolandosi reciprocamente.

“In Prussiani ogni Cliente è speciale e speciale è la macchina che creiamo per lui”

Mario Giorgio Prussiani
CEO - Managing Director



THE COMPANY

L'azienda

In 1991 the dream of Mario Giorgio Prussiani and his wife Mariella Lucchini came true, giving life to Prussiani Engineering: a company that designs and builds high quality numerical control machines for working marble, granite, stone and ceramics.

Over the years the company has grown along with the needs of the market, affirming its presence worldwide. Today it offers advanced and efficient machines, thanks to the constant search for improvement and technological innovation.

Robust and precise made-to-measure machines based on the needs of the individual customer guaranteed up to 5 years. Thanks to a widespread technical-commercial network, present all over the world, the customer assistance is guaranteed before and after the purchase, with speed, professionalism and courtesy.

Prussiani Engineering is sure that the quality of its machines, its patents and the constant sharing of knowledges and experiences between collaborators, customers and suppliers is a guarantee of further expansion.

Nel 1991 il sogno di Mario Giorgio Prussiani e della moglie Mariella Lucchini si è trasformato in realtà dando vita alla *Prussiani Engineering*: un'azienda che *progetta e costruisce macchine a controllo numerico di qualità elevata per la lavorazione di marmi, graniti, pietre e ceramiche*.

Nel corso degli anni l'azienda è cresciuta insieme alle esigenze del mercato, affermando la propria presenza a livello mondiale. Oggi offre *macchine evolute ed efficienti*, grazie alla costante ricerca per il miglioramento e l'innovazione tecnologica.

Macchine robuste e precise, *garantite fino a 5 anni*, realizzate 'su misura' in base alle esigenze del singolo cliente. Grazie ad una capillare *rete tecnico-commerciale*, presente in tutto il mondo, è assicurata l'assistenza prima e dopo l'acquisto, con rapidità, professionalità e cortesia.

La Prussiani Engineering è certa che la qualità delle proprie macchine, dei propri brevetti e la costante condivisione di conoscenze ed esperienze tra collaboratori, Clienti e fornitori sia garanzia di ulteriore espansione.

--->

From 2016 the company can count on a new business partner, Corrado Carrara, a collaborator who grew up in the company.

The professionalism of all workers and the diligence of the new generations will carry on and develop the great project of an Italian company able to combine fantasy and technology, in the conception of their machines and in the unlimited expressive possibilities that these machines guarantee to customers.

Prussiani Engineering:
“The dream continues”.

Dal 2016 può contare su un nuovo socio Corrado Carrara un collaboratore cresciuto in azienda.

La professionalità di tutti i lavoratori e l'impegno delle nuove generazioni porteranno avanti e faranno crescere il grande progetto di un'azienda italiana capace di coniugare *fantasia e tecnologia*, nell'ideazione delle proprie macchine e nelle infinite possibilità espressive che queste macchine garantiscono ai clienti.

Prussiani Engineering:
“Il sogno continua”.



WHY CHOOSE PRUSSIANI

Perché scegliere Prussiani

“PRUSSIANI MACHINES NEVER STOP RUNNING”

Extremely robust and solid machines, built with high quality and long-lasting products. The goal of every singular component is to work at its best and lasting over time. Who buys a Prussiani Engineering machine makes an investment for the future and, when it will buy a new one, it will not be to replace the one already owned, which will continue to work, but to meet the new needs of the market.

ISO 9001 certified company, guarantee of an effective production process for the realization of an excellent product.

“LE MACCHINE PRUSSIANI NON SI FERMANO MAI”

Macchine estremamente robuste, solide, costruite con prodotti di elevata qualità e di lunghissima durata. La finalità di ogni singolo componente è quella di lavorare al meglio, durando nel tempo. Chi compra una macchina Prussiani Engineering fa un investimento per il futuro e, quando ne comperà una nuova, non sarà per rimpiazzare quella già posseduta, che continuerà a lavorare, ma per far fronte a nuove esigenze di mercato. Azienda certificata ISO 9001, garanzia di un processo produttivo efficace per la realizzazione di un prodotto eccellente.

AFTER-SALES ASSISTANCE

Whether an intervention or a spare part is needed, the company provides an after-sales service up to the quality of the machines it produces. Prussiani Engineering is organized to intervene promptly in Italy and abroad in order to help its Customers.

HUMAN RESOURCES

Prussiani Engineering tries to reach a constant enhancement of human resources offering training courses, attention to the individual attitudes and needs. It promotes the organization of events and meetings aimed at promoting group cohesion and strengthening. Its goal is to ensure a safe working environment, reducing the potential risks in carrying out activities and respecting the health of employees. OHSAS18001 certified company.

ENVIRONMENT

Prussiani Engineering contributes to the protection of the environment by supporting virtuous behaviour and promoting the diffusion of the environmental culture. The company operates in the respect of the environment engaging in a constant search for suitable solutions to guarantee the minimum environmental impact linked to the performance of its business activity. Attention to the correct waste separation and consumption control. The factory was built with thermic material and recently LED lighting was installed. Prussiani Engineering supports FAI (Fondo Ambientale Italiano), that protects, enhances and promotes the Italian cultural and landscape heritage within a framework of environmental and economic sustainability.

ART AND CULTURE

Prussiani Engineering supports the Accademia Carrara of Bergamo, one of the most important art galleries in Italy, by 'Quota 15.000'.

This project aims to protect the artistic heritage of the city and to promote the diffusion of beauty through the discovery of art.



ASSISTENZA POST-VENDITA

Ci fosse bisogno di un intervento, o di un pezzo di ricambio, l'azienda fornisce un servizio di assistenza post-vendita all'altezza della qualità delle macchine che produce. Prussiani Engineering è organizzata per intervenire tempestivamente in Italia e all'estero per aiutare i suoi Clienti.

RISORSE UMANE

La Prussiani Engineering cerca di perseguire una costante valorizzazione delle risorse umane, attraverso l'offerta di corsi di formazione, l'attenzione alle singole attitudini e ai singoli bisogni. Promuove l'organizzazione di eventi e ritrovi atti a promuovere la coesione ed il rafforzamento del gruppo. Si prefigge di assicurare un ambiente di lavoro sicuro, riducendo i potenziali rischi nello svolgimento delle attività e rispettando la salute dei collaboratori.

Azienda certificata OHSAS18001.

AMBIENTE

La Prussiani Engineering si impegna a contribuire alla protezione dell'ambiente favorendo comportamenti virtuosi e promuovendo la diffusione della cultura ambientale. L'azienda opera nel rispetto dell'ambiente impegnandosi in una costante ricerca di soluzioni idonee a garantire il minimo impatto ambientale legato allo svolgimento della propria attività di impresa.

Attenzione alla corretta differenziazione dei rifiuti e al controllo dei consumi. Lo stabilimento è stato costruito con materiale termico e recentemente è stata installata l'illuminazione a led.

La Prussiani Engineering sostiene il F.A.I. (Fondo Ambientale Italiano) che tutela, valorizza e promuove il patrimonio paesaggistico e culturale italiano in un quadro di sostenibilità economica e ambientale.

ARTE E CULTURA

La Prussiani Engineering sostiene l'Accademia Carrara di Bergamo, una tra le più importanti pinacoteche d'Italia, attraverso 'Quota 15.000'.

Tale progetto si prefigge l'obiettivo di tutelare il patrimonio artistico della città e di promuovere la divulgazione della bellezza attraverso la scoperta dell'arte.

PRUSSIANI ENGINEERING:
"the dream continues"

PRUSSIANI CNC BRIDGE SAWS

Segatrici a ponte

CHAMPION and **TANGO**, bridge saws with five interpolated axes and **STAR**, bridge saw with four or five interpolated axes, designed and built for the processing of marble, granite, artificial quartz, ceramic and natural stones.

Managed by a **numerical control unit** interfaced with CAD/CAM systems, these saws allow **different types of processing**: Perfect for the production of **unique pieces** or in **series**, STAR, CHAMPION and TANGO bridge **saws** are used primarily for cutting slabs. Tipologies of masterpieces:

- **STRAIGHT CUTS**
- **PROFILES**
- **INCLINED CUTS**
- **CURVED CUTS**
- **HOLES**
- **ENGRAVINGS**
- **BAS-RELIEFS**

CHAMPION and TANGO machinery may be customized according to the Customer's needs about production and space available into his factory.

THE ADVANTAGES

I vantaggi

AUTOMATIC CUTTING AND DISPLACEMENT OF THE PIECES "CUT & MOVE" suction cups manipulator (Prussiani Engineering European Patent EP 1651409)

MACHINE STABILITY AND PERFECT CUTTING QUALITY Bridge moved by two servomotors, one on the right and one on the left (GANTRY system)

MACHINE EASY TO USE
Intuitive CAD/CAM software

GREATER GRIP AND NON-DEFORMABILITY OF WORK TABLES - Top of the working table made of a special Prussiani rubber

EASY AND LOWERED MAINTENANCE
Planning controlled and guided by CNC

NO RISK OF OIL STAINS ON THE MARBLE SLABS
Lubrication with EP1 density grease

ATTENTION TO PEOPLE SAFETY Machines compliant with the most recent safety standards

MACHINES PRODUCED IN ITALY
The Marmo Machine Mark guarantees the Italian excellence of Prussiani machines

UP TO SIXTY MONTHS WORRY-FREE
Three or five years warranty for the mechanical, electrical and electronic components

CHAMPION e TANGO, segatrici a ponte a cinque assi interpolati e STAR, segatrici a ponte a quattro o cinque assi interpolati, sono progettate e costruite per la lavorazione del marmo, del granito, del quarzo artificiale, del materiale ceramico e della pietra in genere.

Gestite da un controllo numerico interfacciato con sistemi CAD/CAM, consentono diverse lavorazioni: Ideali sia per la produzione di pezzi unici che in serie, le segatrici a ponte STAR, CHAMPION e TANGO sono impiegate soprattutto per il taglio di lastre.

Tipologia di lavorazioni:

- **TAGLI RETTILINEI**
- **PROFILATURE**
- **TAGLI INCLINATI**
- **TAGLI CURVI**
- **FORATURE**
- **INCISIONI**
- **BASSORILIEVI**

Le macchine CHAMPION e TANGO possono essere personalizzate in base alle esigenze di produzione e di spazio disponibile nella fabbrica del Cliente.

TAGLIO E SPOSTAMENTO AUTOMATICO DEI PEZZI Manipolatore a ventose "Cut & Move" (Brevetto Europeo Prussiani Engineering EP 1651409)

STABILITÀ DELLA MACCHINA E PERFETTA QUALITÀ DEL TAGLIO

Movimento del ponte tramite due servomotori, uno a destra e uno a sinistra (sistema GANTRY)

FACILITÀ DI UTILIZZO DELLA MACCHINA Software CAD/CAM intuitivi

MAGGIORE GRIP E INDEFORMABILITÀ DELLE TAVOLE DI LAVORO - Piano di lavoro in speciale gomma Prussiani

MANUTENZIONE SEMPLICE E RIDOTTA Pianificazione controllata e guidata dal controllo numerico

NESSUN RISCHIO DI MACCHIE D'OLIO SULLE LASTRE DI MARMO Lubrificazione con grasso di densità EP1

ATTENZIONE ALLA SICUREZZA DELLE PERSONE Macchine rispondenti ai più recenti standard di sicurezza

MACCHINE PRODOTTE IN ITALIA Il Marmo Macchine Mark garantisce l'italianità delle macchine Prussiani

FINO A SESSANTA MESI DI TRANQUILLITÀ Garanzia di tre o cinque anni per i componenti meccanici, elettrici ed elettronici

CNC BRIDGE SAWS

*Segatrici a ponte
a controllo numerico*

EP-PATENTED

CUT & MOVE®

STAR CHAMPION TANGO



VIDEO TRAILER
Bridge Saws



PERFECT
CUTTING



EASY
TO USE



RESISTENCE



MAINTENANCE



NO RISK
OIL STAINS



ATTENTION
SAFETY



CAREFREE



CUSTOMER
CARE



ITALIAN
MADE

WHAT IT IS

The first suction cups manipulator in the world designed and patented by Mario Giorgio Prussiani in 2003 (European Patent Prussiani Engineering EP 1651409).

WHAT IT DOES

It automatically displaces the strips on a working table allowing the disk to perform remaining cuts without hitting closed pieces.

COSA E'

Primo manipolatore a ventose al mondo progettato e brevettato da Mario Giorgio Prussiani nel 2003 (Brevetto Europeo Prussiani Engineering EP 1651409).

COSA FA

Sposta automaticamente le filagne sul banco di lavoro permettendo al disco di eseguire i tagli rimanenti senza incidere i pezzi vicini.

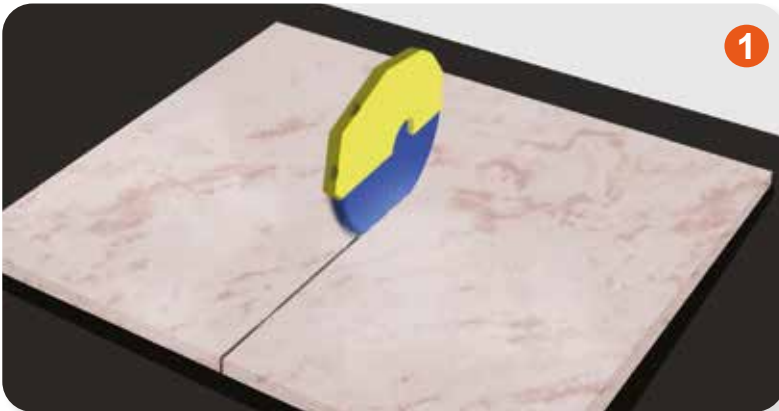

Beginning of preliminary cuts of the slab into strips.

Inizio dei tagli preliminari della lastra in modo da ricavare filagne.

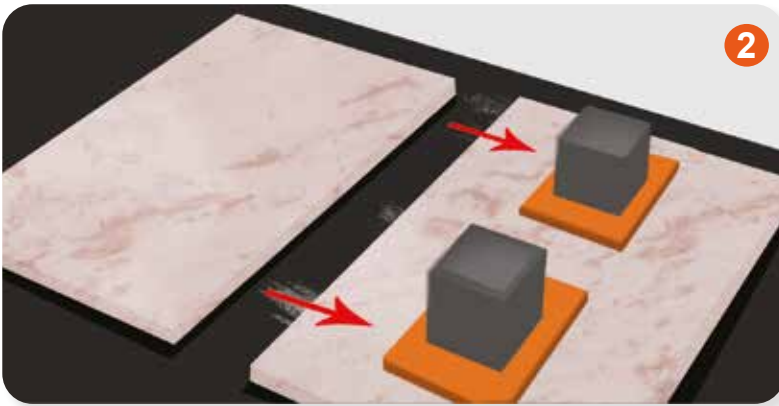

Displacement of strips with the suction cups manipulator Cut & Move.

Spostamento delle filagne tramite il manipolatore a ventose Cut & Move.

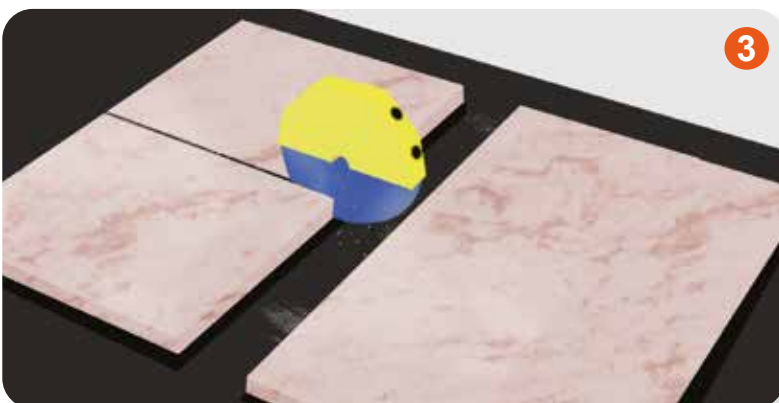

Performing of remaining cut.

Esecuzione del taglio rimanente.



THE ADVANTAGES

The Cut & Move system **REDUCES**:



TIME

- time to organize the work;
- production time.



COSTS

- less wasted material (up to 30%);
- less bridge saws needed;
- less space needed.



RISKS

- reduced physical effort for the operator;
- fewer injuries.

I VANTAGGI

Il sistema Cut & Move **RIDUCE**:

TEMPI

- tempi di organizzazione del lavoro;
- tempi di produzione.

COSTI

- scarto di materiale (fino al 30%);
- numero di segatrici a ponte necessarie;
- spazio occupato.

RISCHI

- minore sforzo fisico dell'operatore;
- meno infortuni.

EXAMPLE A

Produced with manipulator
Prussiani Engineering Patent

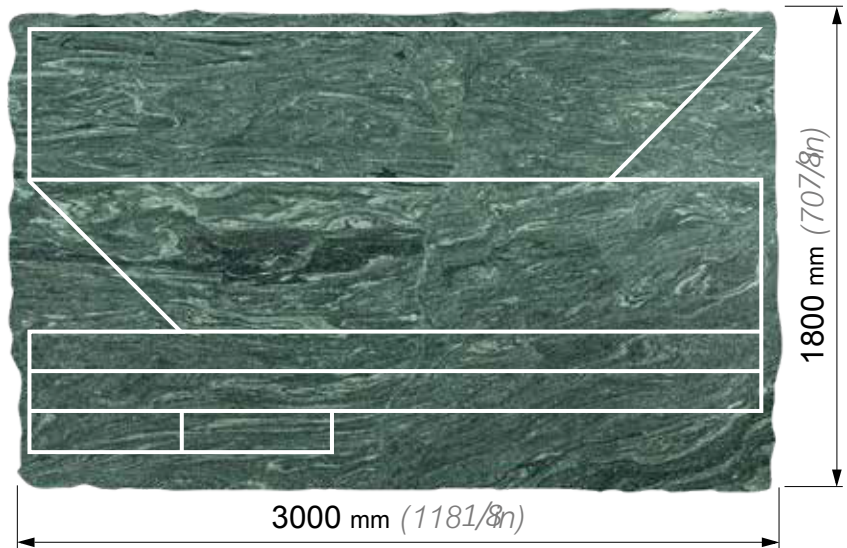

	THICKNESS 20 mm (3/4")		THICKNESS 30 mm (1 1/4")	
	GRANITE	ARTIFICIAL QUARTZ	GRANITE	ARTIFICIAL QUARTZ
STAR PLUS & XL <i>WITH TABLE **</i>	19	24	18	22
CHAMPION 55 <i>WITH TABLE **</i>	19	24	18	22
CHAMPION 55 / CL <i>WITH SIDE LOADING *</i>	24	29	23	27
CHAMPION 55 / SHUTTLE <i>WITH ROTATING TABLES *</i>	33	38	32	36
CHAMPION 65 <i>WITH TABLE **</i>	21	26	20	24
CHAMPION 65 / CL <i>WITH SIDE LOADING *</i>	28	33	27	31
CHAMPION 65 / NT <i>WITH CONVEYOR BELT *</i>	41	46	40	44
NEW CHAMPION 5 <i>WITH TABLE **</i>	21	26	20	24
NEW CHAMPION 5 / CL <i>WITH SIDE LOADING *</i>	28	33	27	31
NEW CHAMPION 5 / 2T <i>WITH TWO TABLES *</i>	42	47	41	45
NEW CHAMPION 5 / NT <i>WITH CONVEYOR BELT *</i>	42	47	41	45
TANGO / NT <i>WITH CONVEYOR BELT *</i>	66	76	64	72

Number of slabs cut as Example A, including time for: slab loading + picture + programming + unloading of the pieces, within 8 working hours up to:

* with these configurations the programming is done while the machine is working.

** on the table versions the programming time can be avoided introducing the slabs check-in photo station. See the optional n. 7 page 37.

PRODUCTION COMPARISON IN 8 WORKING HOURS

Comparazione produttiva in 8 ore di lavoro

EXAMPLE B

Produced with manipulator
Prussiani Engineering Patent

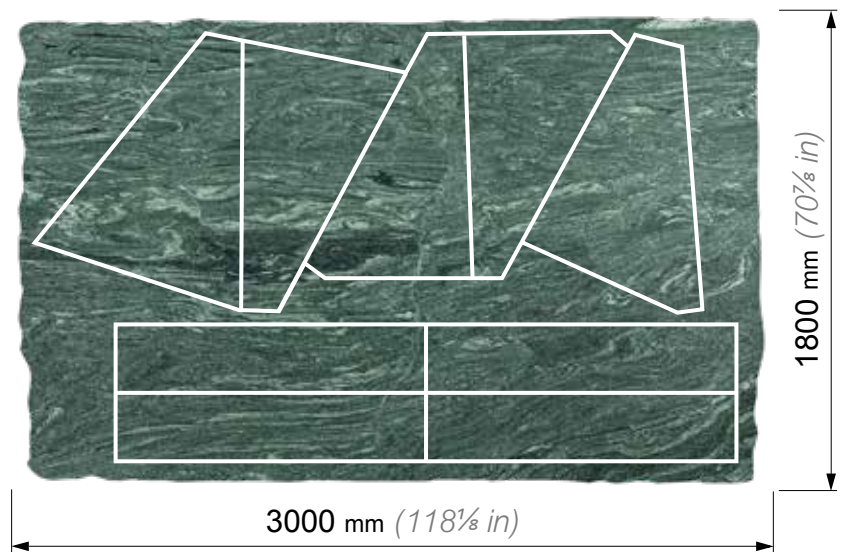

	THICKNESS 20 mm (3/4 in)		THICKNESS 30 mm (1 1/4 in)	
	GRANITE	ARTIFICIAL QUARTZ	GRANITE	ARTIFICIAL QUARTZ
STAR PLUS & XL <i>WITH TABLE **</i>	18	23	17	21
CHAMPION 55 <i>WITH TABLE **</i>	18	23	17	21
CHAMPION 55 / CL <i>WITH SIDE LOADING *</i>	23	28	22	26
CHAMPION 55 / SHUTTLE <i>WITH ROTATING TABLES *</i>	32	37	31	35
CHAMPION 65 <i>WITH TABLE **</i>	20	25	19	23
CHAMPION 65 / CL <i>WITH SIDE LOADING *</i>	27	32	26	30
CHAMPION 65 / NT <i>WITH CONVEYOR BELT *</i>	40	45	39	43
NEW CHAMPION 5 <i>WITH TABLE **</i>	20	26	19	23
NEW CHAMPION 5 / CL <i>WITH SIDE LOADING *</i>	27	33	26	30
NEW CHAMPION 5 / 2T <i>WITH TWO TABLES *</i>	41	47	40	44
NEW CHAMPION 5 / NT <i>WITH CONVEYOR BELT *</i>	41	47	40	44
TANGO / NT <i>WITH CONVEYOR BELT *</i>	64	74	62	70

Number of slabs cut as Example B, including time for: slab loading + picture + programming + unloading of the pieces, within 8 working hours up to:

* with these configurations the programming is done while the machine is working.

** on the table versions the programming time can be avoided introducing the slabs check-in photo station. See the optional n. 7 page 37.

TECHNICAL COMPARISON

Comparazione tecnica

STAR PLUS
STAR XL
**CHAMPION
55**
**CHAMPION
65**
**NEW
CHAMPION 5**
TANGO

X axis stroke <i>Corsa carro asse X</i>	3.600 mm (141 ³ / ₄ in)	3.600 mm (141 ³ / ₄ in)	3.800 mm (149 ⁵ / ₈ in)	3.800 mm (149 ⁵ / ₈ in)	3.800 mm (149 ⁵ / ₈ in)	4.550 mm (179 1/8 in)
Y axis stroke <i>Corsa carro asse Y</i>	2.200 mm (86 ⁵ / ₈ in)	2.600 mm (102 ³ / ₈ in)	2.500 mm (98 ³ / ₈ in)	2.500 mm (98 ³ / ₈ in)	2.500 mm (98 ³ / ₈ in) 6.500 mm (255 ⁷ / ₈ in)	2.500 mm (98 ³ / ₈ in)
Z axis stroke <i>Corsa carro asse Z</i>	350 mm (13 ³ / ₄ in)	350 mm (13 ³ / ₄ in)	350 mm (13 ³ / ₄ in)	450 mm (17 ³ / ₄ in)	400 mm (15 ³ / ₄ in)	400 mm (15 ³ / ₄ in)
A axis rotation <i>Rotazione asse A</i>	-185° + 185° (370°)	-185° + 185° (370°)	- 185° + 185° (370°)	- 185° + 185° (370°)	- 185° + 185° (370°)	- 185° + 185° (370°)
C axis tilting <i>Ribaltamento asse C</i>	0° ÷ 90°	0° ÷ 90°	0° ÷ 90°	0° ÷ 90°	0° ÷ 90°	0° ÷ 90°
X axis rapid speed <i>Velocità in rapido del carro asse X</i>	45 m/min (147,6 fpm)	45 m/min (147,6 fpm)	45 m/min (147,6 fpm)	75 m/min (246 fpm)	65 m/min (213,3 fpm)	65 m/min (213,3 fpm)
Y axis rapid speed <i>Velocità in rapido del carro asse Y</i>	45 m/min (147,6 fpm)	45 m/min (147,6 fpm)	45 m/min (147,6 fpm)	75 m/min (246 fpm)	65 m/min (213,3 fpm)	65 m/min (213,3 fpm)
Z axis rapid speed <i>Velocità in rapido del carro asse Z</i>	10 m/min (32,8 fpm)	10 m/min (32,8 fpm)	10 m/min (32,8 fpm)	8 m/min (26,2 fpm)	11,4 m/min (37,4 fpm)	11,4 m/min (37,4 fpm)
Power electrospindle <i>Potenza elettromandrino portadisco</i>	18 HP S6 (13,2 kW) 72 Nm	18 HP S6 (13,2 kW) 72 Nm	18 HP S6 (13,2 kW) 72 Nm	22,5 HP S6 (16,5 kW) 100 Nm	36 HP S6 (26,4 kW) 170 Nm	36 HP S6 (26,4 kW) 170 Nm
Rpm electrospindle <i>Velocità elettromandrino portadisco</i>	0 ÷ 6.000	0 ÷ 6.000 0 ÷ 8.000 (optional)	0 ÷ 6.000 0 ÷ 8.000 (optional)	0 ÷ 10.000	0 ÷ 8.000	0 ÷ 8.000
Electrospindle tool holder <i>Attacco utensile elettromandrino</i>	1/2" GAS	1/2" GAS ISO 40 (optional)	1/2" GAS ISO 40 (optional)	ISO 40	ISO 40	ISO 40
Max disk diameter <i>Diametro massimo disco</i>	625 mm (24 ⁵ / ₈ in)	625 mm (24 ⁵ / ₈ in)	625 mm (24 ⁵ / ₈ in)	750 mm (29 ¹ / ₂ in)	725 mm (28 ¹ / ₂ in)	725 mm (28 ¹ / ₂ in)
Min disk diameter <i>Diametro minimo disco</i>	350 mm (13 ³ / ₄ in)	350 mm (13 ³ / ₄ in)	350 mm (13 ³ / ₄ in)	350 mm (13 ³ / ₄ in)	350 mm (13 ³ / ₄ in)	350 mm (13 ³ / ₄ in)
Max cutting thickness with disk <i>Taglio spessore massimo disco</i>	215 mm (8 ¹ / ₂ in)	215 mm (8 ¹ / ₂ in)	215 mm (8 ¹ / ₂ in)	260 mm (10 ¹ / ₄ in)	225 mm (8 ⁷ / ₈ in)	225 mm (8 ⁷ / ₈ in)
Max distance table spindle nose <i>Distanza naso mandrino dal tavolo</i>	350 mm (13 ³ / ₄ in)	350 mm (13 ³ / ₄ in)	220 mm (8 ⁵ / ₈ in)	355 mm (14 in)	305 mm (12 in)	305 mm (12 in)
Total absorbed power <i>Potenza massima assorbita totale</i>	18 kW	18 kW	18 kW	24 kW	31 kW	65 kW
Displacement of pieces <i>Spostamento dei pezzi</i>	with manipulator lifting capacity 250 kg	with manipulator lifting capacity 420 kg	with manipulator lifting capacity 420 kg	with manipulator lifting capacity 800 kg	with manipulator lifting capacity 800 kg	with manipulator lifting capacity 800 kg

TABLES & CONVEYOR BELT

Tavole & nastro trasportatore

FIXED TABLE

Tavola fissa

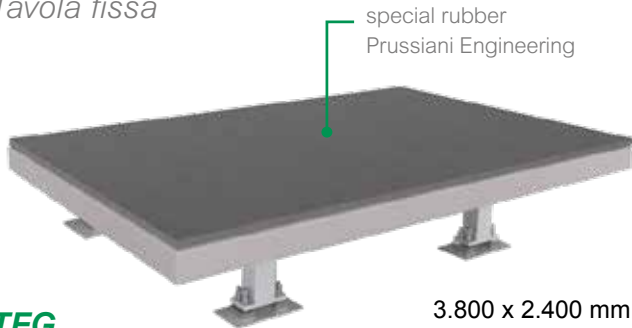

TFG

3.800 x 2.400 mm
(149 5/8 in x 94 1/2 in)

PARTIAL TILTING TABLE

Tavola parzialmente ribaltabile



TPG

3.800 x 2.400 mm
(149 5/8 in x 94 1/2 in)

TABLE WITH TILTING LEVERS

Tavola con leve ribaltabili

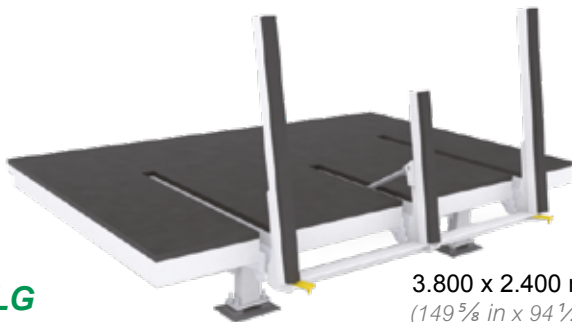

TLG

3.800 x 2.400 mm
(149 5/8 in x 94 1/2 in)

COMPLETELY TILTING TABLE

Tavola completamente ribaltabile



TCG

3.700 x 2.300 mm
(145 5/8 x 90 1/2 in)

SIDE LOADING

Caricatore laterale

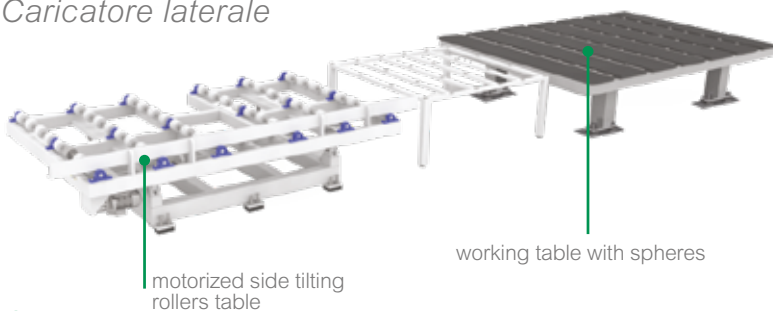

CL

motorized side tilting
rollers table

working table with spheres

ROTATING TABLES

Tavole rotanti

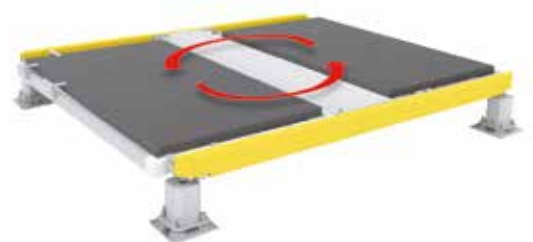

SHUTTLE

TWO TABLES

Due tavole



2T

CONVEYOR BELT

Nastro trasportatore



NT



3 or 5 year warranty for mechanical electric and electronic components

3 o 5 anni di garanzia per i componenti meccanici ed elettronici



Marmo Macchine Mark guarantees the italian excellence of Prussiani machine

Marmo Macchine Mark garantisce l'italianità delle macchine Prussiani



Consolidated experience the first to patent the suction cups manipulator system "CUT&MOVE"

Consolidata esperienza, i primi a brevettare il sistema con manipolatore a ventose "CUT&MOVE"



Prussiani Engineering dynamic company able to professionally and quickly meet its customers needs

Prussiani Engineering, azienda dinamica e capace di rispondere in modo professionale e rapido alle esigenze dei suoi Clienti

STAR PLUS & XL



STAR PLUS & XL

TECHNICAL DATA - STAR PLUS & XL



Dati tecnici - STAR PLUS & XL

X axis stroke <i>Corsa carro asse X</i>	mm (in)	3.600 (141 ³ / ₄)
Y axis stroke – GANTRY <i>Corsa carro asse Y - GANTRY</i>	mm (in)	PLUS 2.200 (86 ⁵ / ₈) XL 2.600 (102 ³ / ₈)
Z axis stroke <i>Corsa carro asse Z</i>	mm (in)	350 (13 ³ / ₄)
A axis rotation <i>Rotazione asse A</i>	degrees gradi	- 185° + 185° (370°)
C axis tilting <i>Ribaltamento asse C</i>	degrees gradi	0° ÷ 90°
X axis rapid speed <i>Velocità in rapido del carro asse X</i>	m/min (fpm)	45 (147,6)
Y axis rapid speed <i>Velocità in rapido del carro asse Y</i>	m/min (fpm)	45 (147,6)
Z axis rapid speed <i>Velocità in rapido del carro asse Z</i>	m/min (fpm)	10 (32,8)
Main disk-holder electrospindle power <i>Potenza elettromandrino portadisco</i>	HP S6 (kW)	18 (13,2)
Main disk-holder electrospindle torque <i>Coppia elettromandrino portadisco</i>	Nm	72
Main disk-holder electrospindle rotation speed <i>Velocità di rotazione elettromandrino portadisco</i>	rpm	0 ÷ 6.000
Electrospindle tool holder <i>Attacco utensile elettromandrino</i>	-	PLUS 1/2" gas XL ISO 40 (optional)
Max disk diameter <i>Diametro massimo del disco</i>	mm (in)	625 (24 ⁵ / ₈)
Axes servomotors for axis X-Y-Z-A-C with absolutes encoder <i>Servomotori per assi X-Y-Z-A-C con encoder assoluti</i>	-	BRUSHLESS

- **Automatic centralized greased lubrication. In case of anomalies the machine stops;**
Lubrificazione centralizzata automatica a grasso. In caso di anomalie la macchina si arresta.
- **Watertight IP 55 electric cabinet with safety thermostat;**
Armadio elettrico a tenuta stagna IP 55 e termostato di sicurezza.
- **Sound power level: 80 ÷ 90 dB(A);**
Livello di potenza sonora: 80 ÷ 90 dB(A).

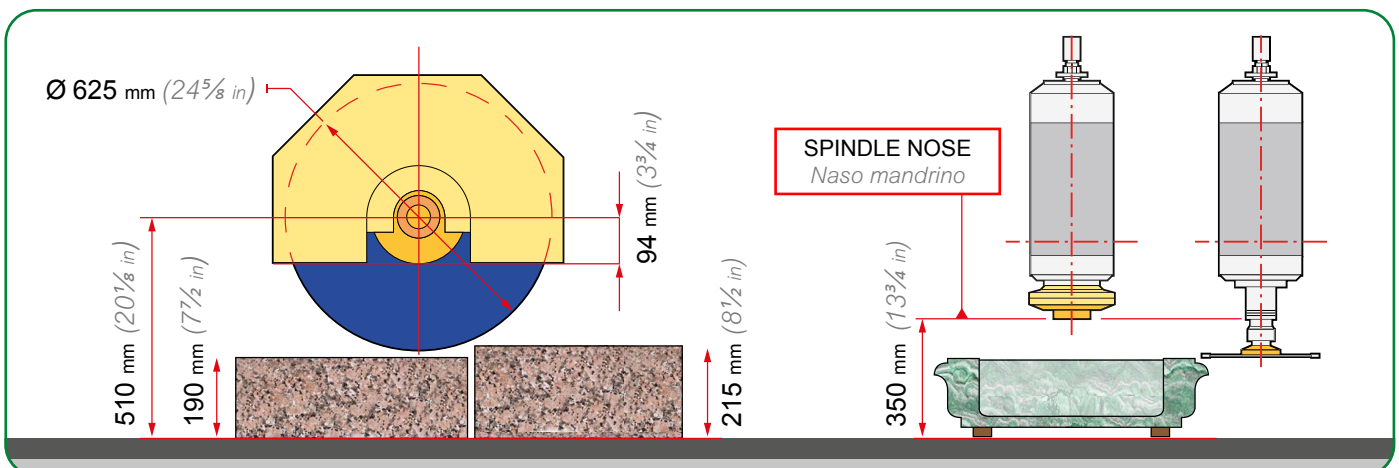

STAR XL

with table

Max total adsorbed power	18 kW
Approximate total weight	5.000 kg (11.023 lb)
Length	5.750 mm (226 ³ / ₈ in)
Width	4.250 mm (167 ³ / ₈ in)
Height	2.700 mm (106 ¹ / ₄ in)
Height with camera	2.800 mm (110 ¹ / ₄ in)
Capacity suction cups	420 kg (926 lb)
Minimum width for lifting <i>Optional*</i>	120 mm (4 ³ / ₄ in) 50 mm (2 in)

MONOBLOC STRUCTURE
Struttura monoblocco

STAR PLUS

with table

Max total adsorbed power	18 kW
Approximate total weight	4.600 kg (10.141 lb)
Length	5.550 mm (218 ¹ / ₂ in)
Width	3.550 mm (139 ³ / ₄ in)
Height	2.700 mm (106 ¹ / ₄ in)
Height with camera	2.800 mm (110 ¹ / ₄ in)
Capacity suction cups	250 kg (551 lb)
Minimum width for lifting	90 mm (3 ¹ / ₂ in)

MONOBLOC STRUCTURE
Struttura monoblocco





3 or 5 year warranty for mechanical electric and electronic components

3 o 5 anni di garanzia per i componenti meccanici ed elettronici



Marmo Macchine Mark guarantees the italian excellence of Prussiani machine

Marmo Macchine Mark garantisce l'italianità delle macchine Prussiani



Consolidated experience the first to patent the suction cups manipulator system "CUT&MOVE"

Consolidata esperienza, i primi a brevettare il sistema con manipolatore a ventose "CUT&MOVE"



Prussiani Engineering dynamic company able to professionally and quickly meet its customers needs

Prussiani Engineering, azienda dinamica e capace di rispondere in modo professionale e rapido alle esigenze dei suoi Clienti

CHAMPION 55



CHAMPION 55

TECHNICAL DATA - CHAMPION 55



Dati tecnici - CHAMPION 55

X axis stroke <i>Corsa carro asse X</i>	mm (in)	3.800 (149 ⁵ / ₈)
Y axis stroke – GANTRY <i>Corsa carro asse Y - GANTRY</i>	mm (in)	2.500 (98 ³ / ₈)
Z axis stroke <i>Corsa carro asse Z</i>	mm (in)	350 (13 ³ / ₄)
A axis rotation <i>Rotazione asse A</i>	degrees gradi	- 185° + 185° (370°)
C axis tilting <i>Ribaltamento asse C</i>	degrees gradi	0° ÷ 90°
X axis rapid speed <i>Velocità in rapido del carro asse X</i>	m/min (fpm)	45 (147,6)
Y axis rapid speed <i>Velocità in rapido del carro asse Y</i>	m/min (fpm)	45 (147,6)
Z axis rapid speed <i>Velocità in rapido del carro asse Z</i>	m/min (fpm)	10 (32,8)
Main disk-holder electrospindle power <i>Potenza elettromandrino portadisco</i>	HP S6 (kW)	18 (13,2)
Main disk-holder electrospindle torque <i>Coppia elettromandrino portadisco</i>	Nm	72
Main disk-holder electrospindle rotation speed – Standard <i>Velocità di rotazione elettromandrino portadisco - Standard</i>	rpm	0 ÷ 6.000
Main disk-holder electrospindle rotation speed – Optional <i>Velocità di rotazione elettromandrino portadisco - Optional</i>	rpm	0 ÷ 8.000
Electrospindle tool holder – Standard <i>Attacco utensile elettromandrino – Standard</i>	-	1/2" gas
Electrospindle tool holder – Optional <i>Attacco utensile elettromandrino – Optional</i>	-	ISO 40
Max disk diameter <i>Diametro massimo del disco</i>	mm (in)	625 (24 ⁵ / ₈)
Axes servomotors for axis X-Y-Z-A-(C) with absolutes encoder <i>Servomotori per assi X-Y-Z-A-(C) con encoder assoluti</i>	-	BRUSHLESS

- **Automatic centralized greased lubrication. In case of anomalies the machine stops;**
Lubrificazione centralizzata automatica a grasso. In caso di anomalie la macchina si arresta.
- **Watertight IP 55 electric cabinet with safety thermostat;**
Armadio elettrico a tenuta stagna IP 55 e termostato di sicurezza.
- **Sound power level: 80 ÷ 90 dB(A);**
Livello di potenza sonora: 80 ÷ 90 dB(A).

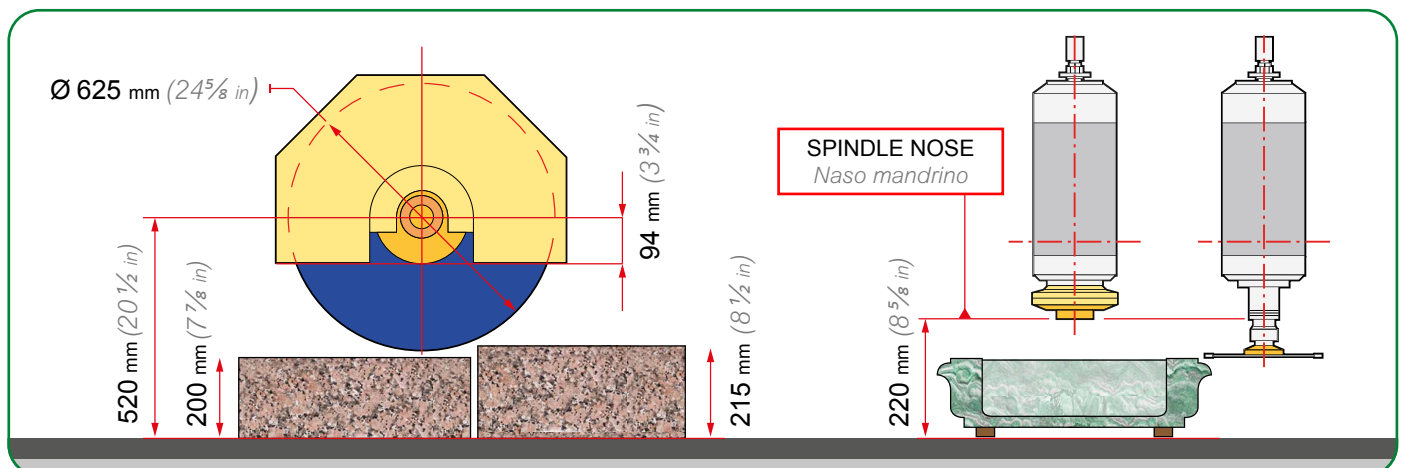

CHAMPION 55

with table



Max total adsorbed power	18 kW
Approximate total weight	4.900 kg (10.802 lb)
Length	6.600 mm (259 1/4 in)
Width	4.300 mm (169 1/4 in)
Height	2.900 mm (114 1/4 in)
Capacity suction cups	420 kg (926 lb)
Minimum width for lifting	120 mm (4 3/4 in)
Optional *	* 50 mm (2 in)

CHAMPION 55/CL

with side loading



side tilting table
with spheres

Max total adsorbed power	20 kW	Width	4.300 mm (139 3/4 in)
Approximate total weight	6.900 kg (15.211 lb)	Height	2.900 mm (114 1/4 in)
Length	11.400 mm (448 3/4 in)	Capacity suction cups	420 kg (926 lb)
		Minimum width for lifting	120 mm (4 3/4 in)
		Optional *	* 50 mm (2 in)

CHAMPION 55/SHUTTLE

with rotating tables



Max total adsorbed power	18 kW
Approximate total weight	10.800 kg (23.809 lb)
Length	8.400 mm (330 3/4 in)
Width	7.600 mm (299 1/4 in)
Height	2.900 mm (114 1/4 in)
Capacity suction cups	420 kg (926 lb)
Minimum width for lifting	120 mm (4 3/4 in)
Optional *	* 50 mm (2 in)



3 or 5 year warranty for mechanical electric and electronic components

3 o 5 anni di garanzia per i componenti meccanici ed elettronici



Marmo Macchine Mark guarantees the Italian excellence of Prussiani machine

Marmo Macchine Mark garantisce l'italianità delle macchine Prussiani



Consolidated experience the first to patent the suction cups manipulator system "CUT&MOVE"

Consolidata esperienza, i primi a brevettare il sistema con manipolatore a ventose "CUT&MOVE"



Prussiani Engineering dynamic company able to professionally and quickly meet its customers needs

Prussiani Engineering, azienda dinamica e capace di rispondere in modo professionale e rapido alle esigenze dei suoi Clienti

CHAMPION 65



CHAMPION 65

TECHNICAL DATA - CHAMPION 65



Dati tecnici - CHAMPION 65

X axis stroke <i>Corsa carro asse X</i>	mm (in)	3.800 (149 ⁵ / ₈)
Y axis stroke – GANTRY <i>Corsa carro asse Y - GANTRY</i>	mm (in)	2.500 (98 ³ / ₈)
Z axis stroke <i>Corsa carro asse Z</i>	mm (in)	450 (17 ³ / ₄)
A axis rotation <i>Rotazione asse A</i>	degrees gradi	- 185° + 185° (370°)
C axis tilting <i>Ribaltamento asse C</i>	degrees gradi	0° ÷ 90°
X axis rapid speed <i>Velocità in rapido del carro asse X</i>	m/min (fpm)	75 (147,6)
Y axis rapid speed <i>Velocità in rapido del carro asse Y</i>	m/min (fpm)	75 (147,6)
Z axis rapid speed <i>Velocità in rapido del carro asse Z</i>	m/min (fpm)	8 (32,8)
Main disk-holder electrospindle power <i>Potenza elettromandrino portadisco</i>	HP S6 (kW)	22,5 (16,5)
Main disk-holder electrospindle torque <i>Coppia elettromandrino portadisco</i>	Nm	100
Main disk-holder electrospindle rotation speed <i>Velocità di rotazione elettromandrino portadisco</i>	rpm	0 ÷ 10.000
Electrospindle tool holder <i>Attacco utensile elettromandrino</i>	-	ISO 40
Max disk diameter <i>Diametro massimo del disco</i>	mm (in)	750 (29 ¹ / ₂)
Axes servomotors for axis X-Y-Z-A-C with absolutes encoder <i>Servomotori per assi X-Y-Z-A-C con encoder assoluti</i>	-	BRUSHLESS

- **Automatic centralized greased lubrication. In case of anomalies the machine stops;**
Lubrificazione centralizzata automatica a grasso. In caso di anomalie la macchina si arresta.
- **Watertight IP 55 electric cabinet with safety thermostat;**
Armadio elettrico a tenuta stagna IP 55 e termostato di sicurezza.
- **Sound power level: 80 ÷ 90 dB(A);**
Livello di potenza sonora: 80 ÷ 90 dB(A).

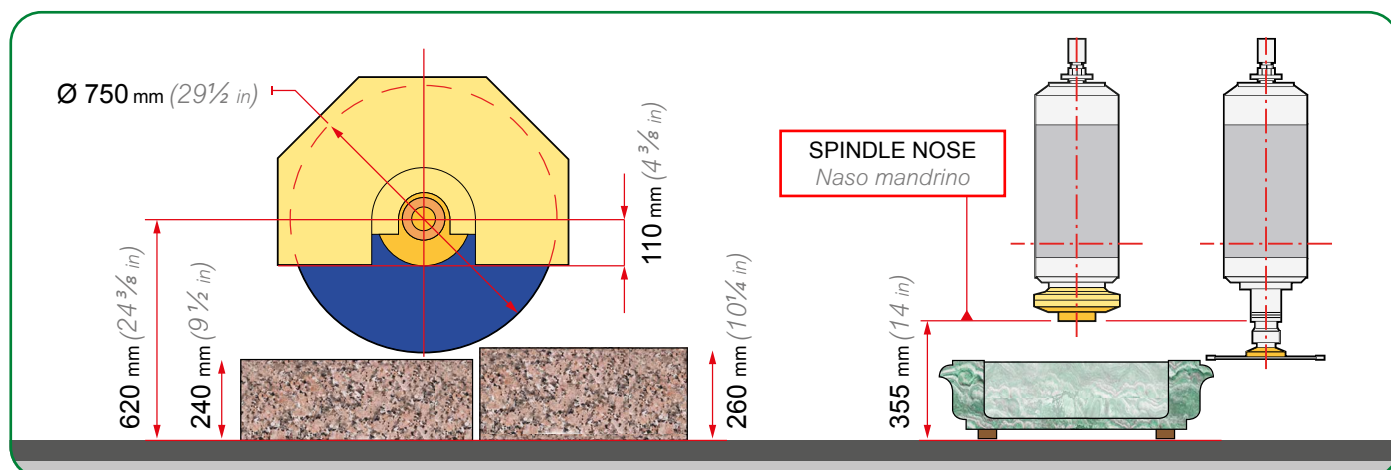

CHAMPION 65

with table



Max total adsorbed power	24 kW
Approximate total weight	5.200 kg (11.500)
Length	6.900 mm (271 $\frac{1}{8}$ in)
Width	4.470 mm (176 in)
Height	3.270 mm (128 $\frac{3}{4}$ in)
Maximum capacity suction cups	800 kg (1.763 lb)
Minimum width for lifting	50 mm (2 in)

CHAMPION 65/CL

with side loading



side tilting table with spheres

Max total adsorbed power	26 kW	Width	4.470 mm (176 in)
Approximate total weight	8.500 kg (18.750 lb)	Height	3.270 mm (128 $\frac{3}{4}$ in)
Length	10.900 mm (429 $\frac{1}{8}$ in)	Maximum capacity suction cups	800 kg (1.763 lb)
		Minimum width for lifting	50 mm (2 in)

Max total adsorbed power	26 kW
Approximate total weight	11.200 kg (24.700 lb)
Length	14.400 mm (566 $\frac{7}{8}$ in)
Width	4.470 mm (176 in)
Height	3.270 mm (128 $\frac{3}{4}$ in)
Maximum capacity suction cups	800 kg (1.763 lb)
Minimum width for lifting	50 mm (2 in)

CHAMPION 65/NT

with conveyor belt + motorized side tilting rollers table





3 or 5 year warranty
for mechanical electric
and electronic
components

3 o 5 anni di garanzia per i componenti
meccanici ed elettronici



**Marmo Macchine
Mark** guarantees the
italian excellence of
Prussiani machine

Marmo Macchine Mark garantisce
l'italianità delle macchine Prussiani



Consolidated experience
the first to patent the
suction cups manipulator
system "CUT&MOVE"

Consolidata esperienza, i primi a brevettare il
sistema con manipolatore a ventose "CUT&MOVE"



Prussiani Engineering
dynamic company able to
professionally and quickly
meet its customers needs

Prussiani Engineering, azienda dinamica e
capace di rispondere in modo professionale
e rapido alle esigenze dei suoi Clienti

NEW CHAMPION 5



NEW CHAMPION 5

TECHNICAL DATA - NEW CHAMPION 5



Dati tecnici - NEW CHAMPION 5

X axis stroke <i>Corsa carro asse X</i>	mm (in)	3.800 (149 ⁵ / ₈)
Y axis stroke – GANTRY <i>Corsa carro asse Y - GANTRY</i>	mm (in)	2.500 (98 ³ / ₈)
Z axis stroke <i>Corsa carro asse Z</i>	mm (in)	400 (15 ³ / ₄)
A axis rotation <i>Rotazione asse A</i>	degrees gradi	- 185° + 185° (370°)
C axis tilting <i>Ribaltamento asse C</i>	degrees gradi	0° ÷ 90°
X axis rapid speed <i>Velocità in rapido del carro asse X</i>	m/min (fpm)	65 (213,3)
Y axis rapid speed <i>Velocità in rapido del carro asse Y</i>	m/min (fpm)	65 (213,3)
Z axis rapid speed <i>Velocità in rapido del carro asse Z</i>	m/min (fpm)	11,4 (37,4)
Main disk-holder electrospindle power <i>Potenza elettromandrino portadisco</i>	HP S6 (kW)	36 (26,4)
Main disk-holder electrospindle torque <i>Coppia elettromandrino portadisco</i>	Nm	170
Main disk-holder electrospindle rotation speed <i>Velocità di rotazione elettromandrino portadisco</i>	rpm	0 ÷ 8.000
Electrospindle tool holder <i>Attacco utensile elettromandrino</i>	-	ISO 40
Max disk diameter <i>Diametro massimo del disco</i>	mm (in)	725 (28 ¹ / ₂)
Axes servomotors for axis X-Y-Z-A-C with absolutes encoder <i>Servomotori per assi X-Y-Z-A-C con encoder assoluti</i>	-	BRUSHLESS

- **Automatic centralized greased lubrication. In case of anomalies the machine stops;**
Lubrificazione centralizzata automatica a grasso. In caso di anomalie la macchina si arresta.
- **Watertight IP 55 electric cabinet with safety thermostat;**
Armadio elettrico a tenuta stagna IP 55 e termostato di sicurezza.
- **Sound power level: 80 ÷ 90 dB(A);**
Livello di potenza sonora: 80 ÷ 90 dB(A).

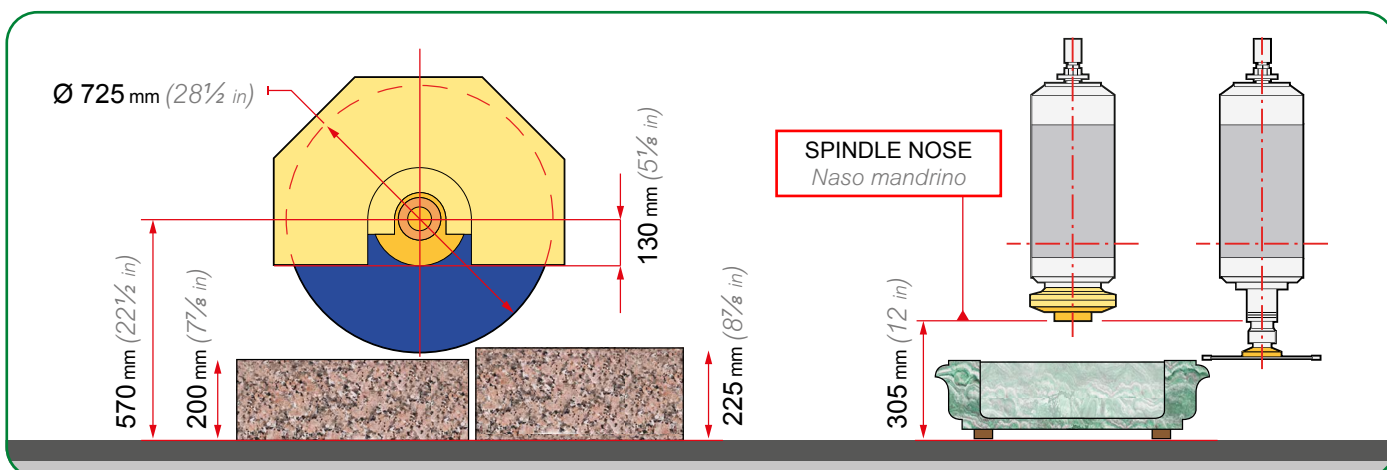

NEW CHAMPION 5

with table



Y axis stroke GANTRY	2.500 mm (98 $\frac{1}{2}$ in)
Max total adsorbed power	31 kW
Approximate total weight	7.500 kg (16.550 lb)
Length	6.925 mm (272 $\frac{5}{8}$ in)
Width	5.100 mm (200 $\frac{3}{4}$ in)
Height	3.700 mm (145 $\frac{5}{8}$ in)
Capacity suction cups	800 kg (1.763 lb)
Minimum width for lifting	50 mm (2 in)

NEW CHAMPION 5/CL

with side loading



roller table (optional)

motorized side tilting rollers table

Y axis stroke GANTRY	2.500 mm (98 $\frac{1}{2}$ in)	Approximate total weight	8.500 kg (18.750 lb)	Capacity suction cups	800 kg (1.763 lb)
Max total adsorbed power	33 kW	Length	14.150 mm (557 $\frac{1}{8}$ in)	Minimum width for lifting	50 mm (2 in)

Width	5.100 mm (200 $\frac{3}{4}$ in)
Height	3.700 mm (145 $\frac{5}{8}$ in)

NEW CHAMPION 5/2T

with two tables



Y axis stroke GANTRY	6.500 mm (255 $\frac{7}{8}$ in)
Max total adsorbed power	33 kW
Approximate total weight	11.500 kg (25.350 lb)
Length	6.926 mm (272 $\frac{5}{8}$ in)
Width	9.350 mm (368 $\frac{1}{8}$ in)
Height	3.700 mm (145 $\frac{5}{8}$ in)
Capacity suction cups	800 kg (1.763 lb)
Minimum width for lifting	50 mm (2 in)

NEW CHAMPION 5 / NT

with conveyor belt + motorized side tilting rollers table

Y axis stroke GANTRY	2.500 mm (98 3/8 in)
Max total adsorbed power	31 kW
Approximate total weight	12.300 kg (27.150 lb)
Length	15.200 mm (598 3/8 in)
Width	5.100 mm (200 3/4 in)
Height	3.700 mm (145 5/8 in)
Capacity suction cups	800 kg (1.763 lb)
Minimum width for lifting	50 mm (2 in)



NEW CHAMPION 5 / NT + CA

with conveyor belt + automatic slabs loader

Y axis stroke GANTRY	2.500 mm (98 3/8 in)
Max total adsorbed power	40 kW
Approximate total weight	13.500 kg (29.770 lb)
Length	15.200 mm (598 3/8 in)
Width	6.000 mm (236 1/4 in)
Height	3.700 mm (145 5/8 in)
Capacity suction cups	800 kg (1.763 lb)
Minimum width for lifting	50 mm (2 in)



CUSTOMIZED MACHINES

Macchine personalizzate

1

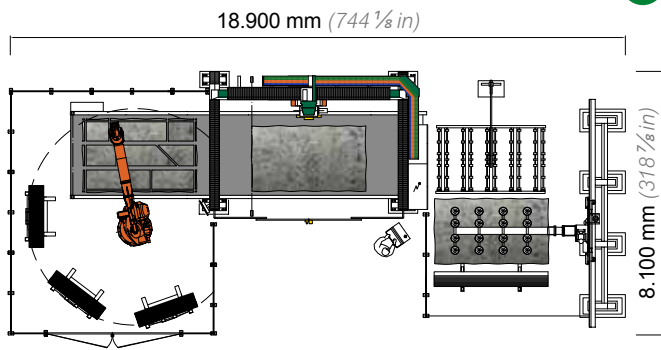

With automatic loader of the book/match slabs and unloading robot.

2

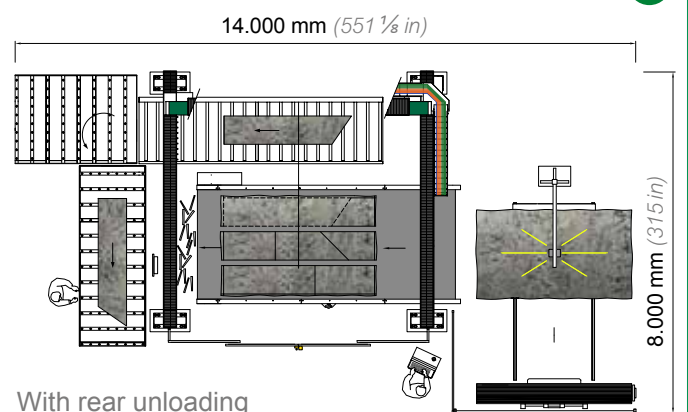

With rear unloading and automatic slabs loader.

3

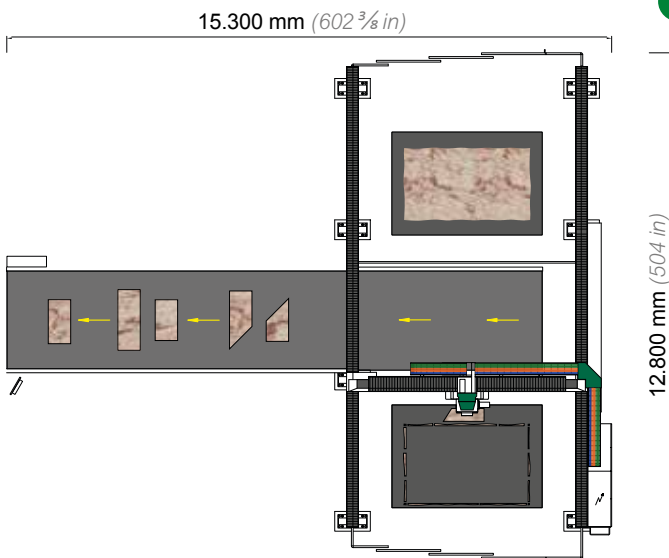

With two tables and unloading belt.

4

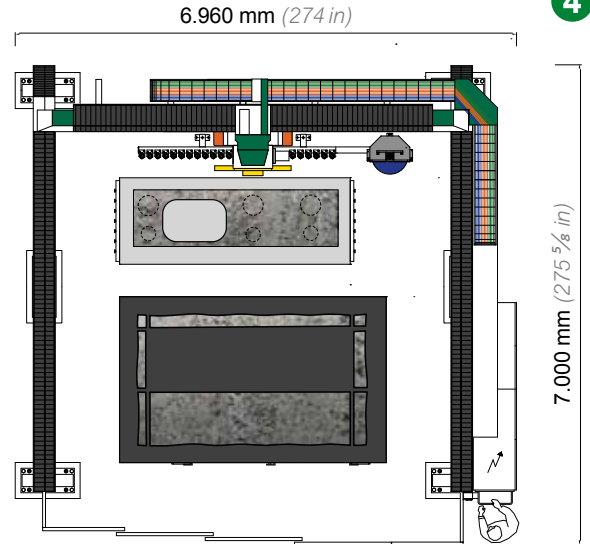

With aluminium table for kitchen and vanity tops.

5

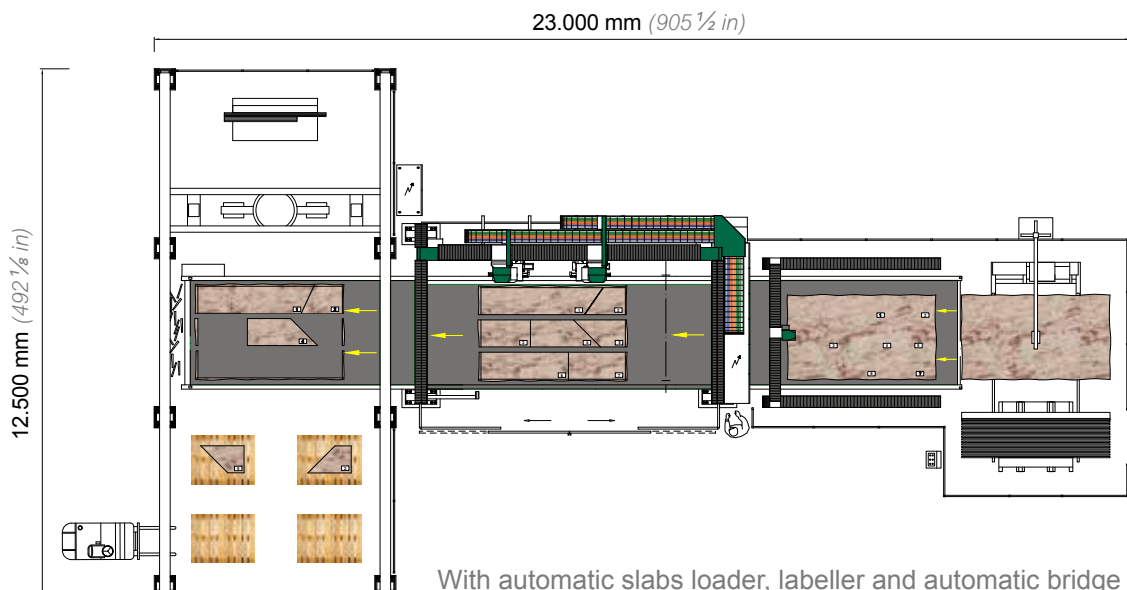

With automatic slabs loader, labeller and automatic bridge unloader.



3 or 5 year warranty for mechanical electric and electronic components

3 o 5 anni di garanzia per i componenti meccanici ed elettronici



Marmo Macchine Mark guarantees the italian excellence of Prussiani machine

Marmo Macchine Mark garantisce l'italianità delle macchine Prussiani



Consolidated experience the first to patent the suction cups manipulator system "CUT&MOVE"

Consolidata esperienza, i primi a brevettare il sistema con manipolatore a ventose "CUT&MOVE"



Prussiani Engineering dynamic company able to professionally and quickly meet its customers needs

Prussiani Engineering, azienda dinamica e capace di rispondere in modo professionale e rapido alle esigenze dei suoi Clienti

TANGO



TANGO

TECHNICAL DATA - TANGO



Dati tecnici - TANGO

X axis stroke <i>Corsa carro asse X</i>	mm (in)	4.550 (179 1/8)
Y axis stroke – GANTRY <i>Corsa carro asse Y - GANTRY</i>	mm (in)	2.500 (98 3/8)
Z axis stroke <i>Corsa carro asse Z</i>	mm (in)	400 (15 3/4)
A axis rotation <i>Rotazione asse A</i>	degrees gradi	- 185° + 185° (370°)
C axis tilting <i>Ribaltamento asse C</i>	degrees gradi	0° ÷ 90°
X axis rapid speed <i>Velocità in rapido del carro asse X</i>	m/min (fpm)	65 (213,3)
Y axis rapid speed <i>Velocità in rapido del carro asse Y</i>	m/min (fpm)	65 (213,3)
Z axis rapid speed <i>Velocità in rapido del carro asse Z</i>	m/min (fpm)	11,4 (37,4)
Main disk-holder electrospindle power <i>Potenza elettromandrino portadisco</i>	HP S6 (kW)	36 (26,4)
Main disk-holder electrospindle torque <i>Coppia elettromandrino portadisco</i>	Nm	170
Main disk-holder electrospindle rotation speed <i>Velocità di rotazione elettromandrino portadisco</i>	rpm	0 ÷ 8.000
Electrospindle tool holder <i>Attacco utensile elettromandrino</i>	-	ISO 40
Max disk diameter <i>Diametro massimo del disco</i>	mm (in)	725 (28 1/2)
Axes servomotors for axis X-Y-Z-A-C with absolute encoder <i>Servomotori per assi X-Y-Z-A-C con encoder assoluti</i>	-	BRUSHLESS

- **Automatic centralized greased lubrication. In case of anomalies the machine stops;**
Lubrificazione centralizzata automatica a grasso. In caso di anomalie la macchina si arresta.
- **Watertight IP 55 electric cabinet with safety thermostat;**
Armadio elettrico a tenuta stagna IP 55 e termostato di sicurezza.
- **Sound power level: 80 ÷ 90 dB(A);**
Livello di potenza sonora: 80 ÷ 90 dB(A).

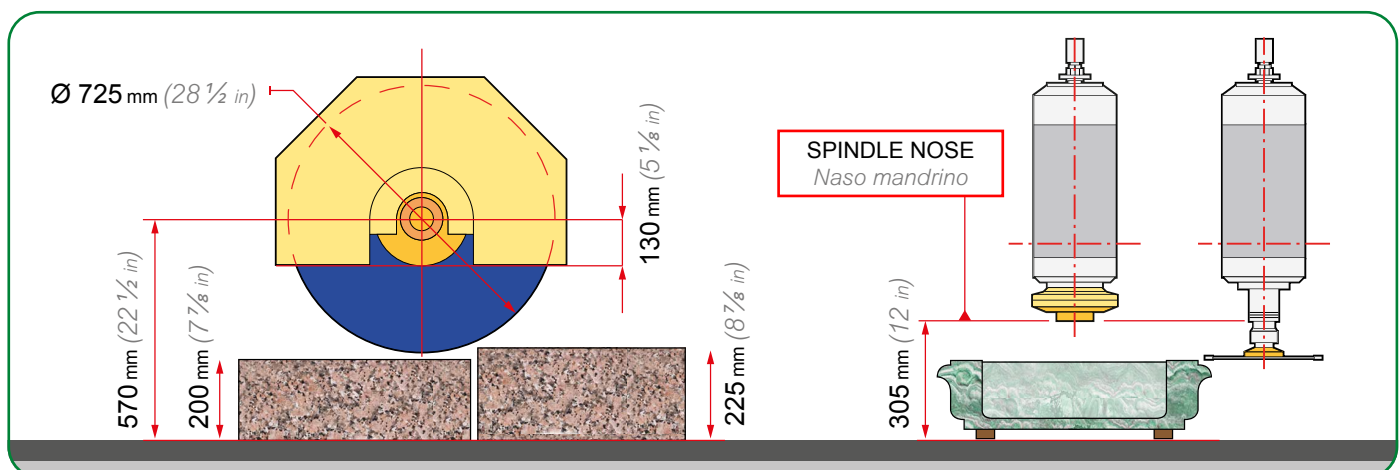

TANGO

Y axis stroke GANTRY	4.550 mm (179 1/8 in)
Max total adsorbed power	65 kW
Approximate total weight	15.000 kg (33.070 lb)
Length	17.000 mm (669 1/4 in)
Width	5.150 mm (202 3/4 in)
Height	3.700 mm (145 5/8 in)
Capacity suction cups	800 kg (1.763 lb)
Minimum width for lifting	50 mm (2 in)



INNOVATIVE DEVICES

Dispositivi innovativi



Kit for vanity and kitchen tops.

Kit per la lavorazione di piani da bagno e cucina.



Cutting unit for reinforcement bar complete with disk diameter 400 mm (15 $\frac{3}{4}$ in) for granite.

Gruppo per esecuzione canalini sottopiano completo di disco diametro 400 mm per granito.



Laser beam showing cutting line, positioned on the rotating head.

Laser segnataglio fissato sulla testa rotante.

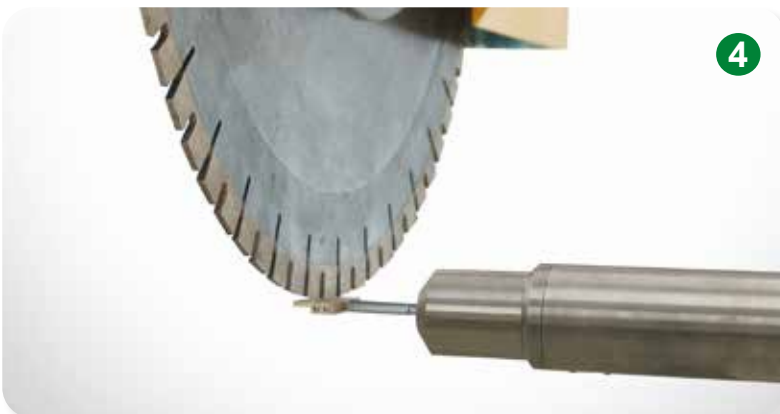

Electronic presetting feeler for automatic measuring of the disk diameter.

Sonda presetting per la misurazione automatica del diametro del disco.



5

Camera with protective pressurized cover.

Macchina fotografica con box di protezione pressurizzato.



6

Electronic feeler for automatic measuring of the thickness of the slab to cut indispensable for a perfect cutting at 45°.

Sonda elettronica per la misurazione automatica dello spessore della lastra da tagliare indispensabile per un perfetto taglio a 45°.



7

Save programming time by taking pictures of your slabs in advance, thanks to the special slabs "check-in" photo-system.

Your digital slabs will be ready to use for programming cuts at any time.

Risparmia tempo di programmazione salvando le foto delle lastre in anticipo, grazie allo speciale sistema di "check-in" lastre. Le tue lastre digitali saranno pronte all'uso in qualsiasi momento per la programmazione tagli.



8

Manipulator Dual-Zone with suction cups for the automatic movement of the work-pieces. Prussiani Engineering European Patent EP 1651409.

Manipolatore a ventose BI-ZONA per lo spostamento automatico pezzi.

Brevetto Europeo Prussiani Engineering EP 1651409.

CUT & MOVE®



Stonapp® & CRM

Prussiani's **Stonapp®** & CRM

Funziona su smartphone e tablet

Stonapp® the APP for being informed on the productivity of your Prussiani machines

CRM: the APP for an excellent organization of after-sales service, for buying spare parts and receiving answers to your questions.

Stonapp® la APP per essere informati sulla produttività delle vostre macchine Prussiani.

CRM: la APP per un'eccellente organizzazione del servizio post-vendita, per l'acquisto di pezzi di ricambio e per ricevere risposte alle vostre domande.



CNC BRIDGE SAWS

SEGATRICI A PONTE CNC

CNC MILLING MACHINES

FRESATRICI A PONTE CNC

CNC CUT&JET COMBINED

COMBinate CUT&JET CNC

CNC WATERJET

GETTO D'ACQUA CNC

CNC WORKING CENTERS

CENTRI DI LAVORO CNC

CNC SINK HOLE MACHINES

MACCHINE PER FORI LAVANDINI CNC

CNC LATHES

TORNI CNC

CNC SLABS POLISHING MACHINES

LUCIDALASTRE CNC

EDGE POLISHING MACHINES

LUCIDACOSTE

**AUTOMATIC LOADING OF SLABS
WITH ANTHROPOMORPHIC ROBOT**

CARICO AUTOMATICO DELLE LASTRE
CON ROBOT ANTROPOMORFO

**AUTOMATIC STORAGES
FOR SINGLE SLABS**

MAGAZZINI AUTOMATICI PER SINGOLE LASTRE



Prussiani Engineering S.p.A

Via Luigi Galvani, 16 24061

Albano Sant'Alessandro (Bergamo) Italy

+39 035 581444 | info@prussiani.com

www.prussiani.com

